

READ ME FIRST

Follow the tips below to ensure you get the most enjoyment from your IMPACT unicycle!

1

Saddle assembly

Seat clamp must be tightened correctly! If the seat clamp is not tight enough the seat post will twist. If it is too tight the seat post will be bent out of shape.

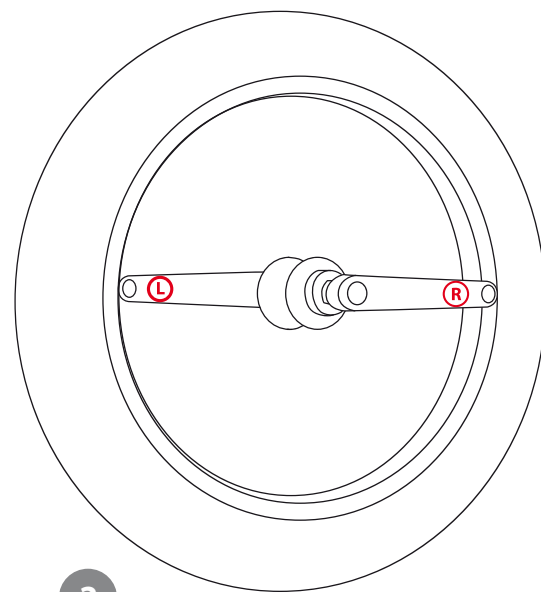
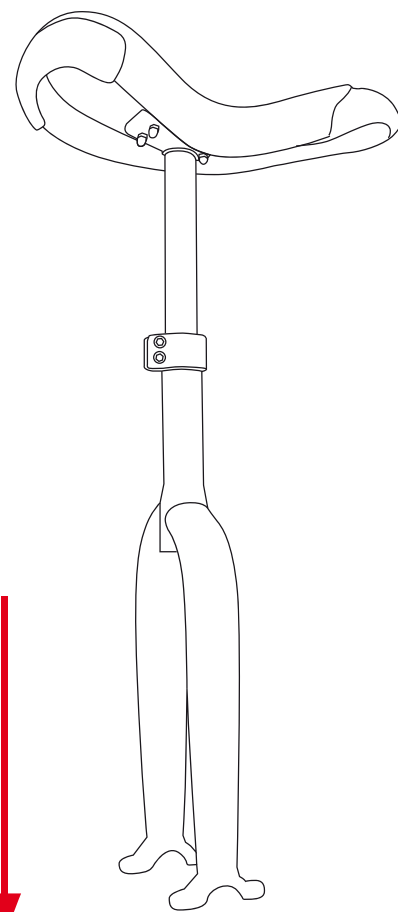
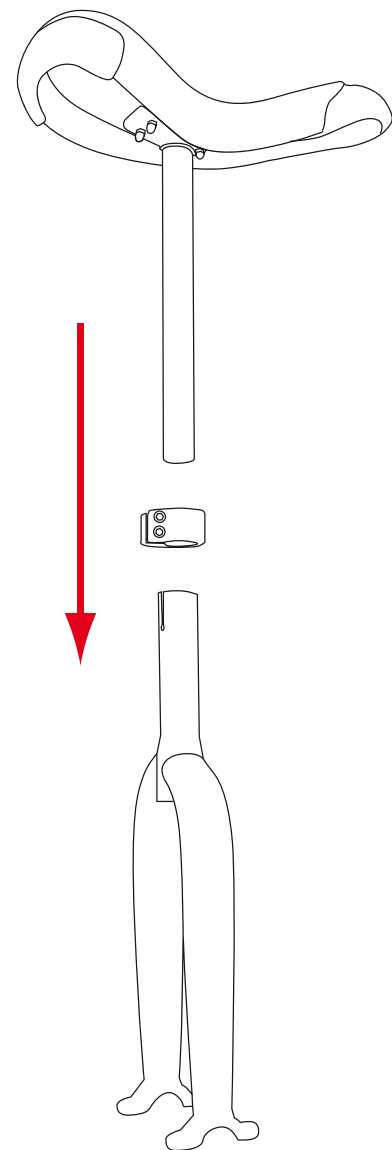

2

Frame position on the wheel

Direction of the wheel and frame are important! The back of the frame has a slot for the seat clamp. There is an R and an L on the cranks to show the wheel sides.

3

Attaching the wheel

Frame bolts must be tightened correctly! If the bearing housings are too tight it will damage the bearings and the wheel will not spin freely if at all. If the bearing housings are not tight enough, there will be excessive movement and noise.

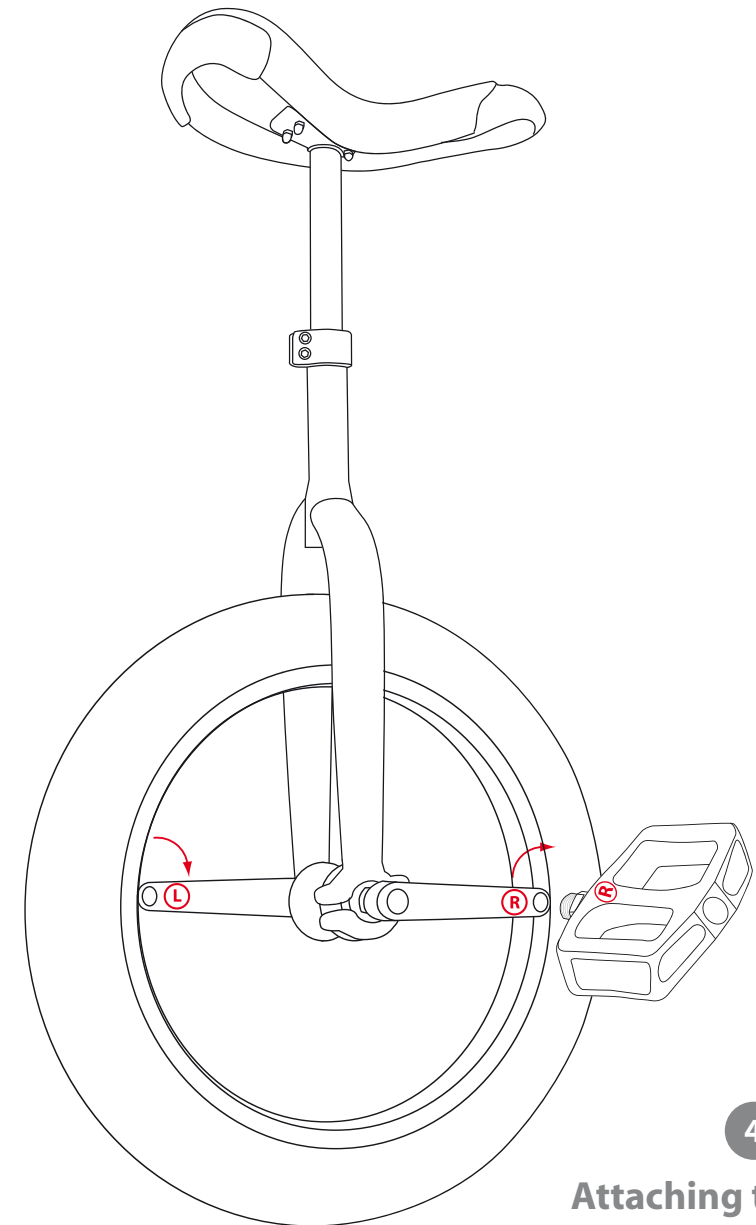
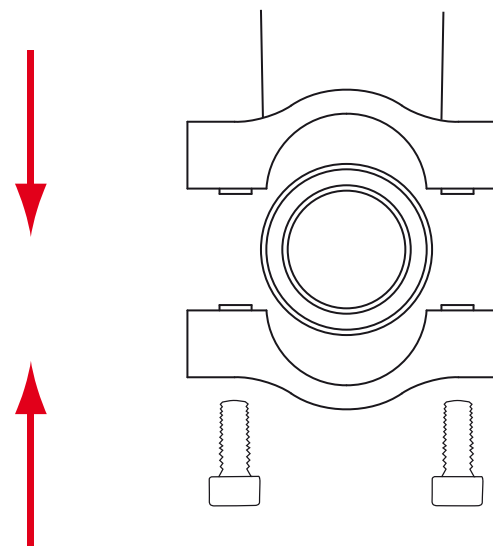

4

Attaching the pedals

Both pedals are not the same! There is a left pedal for the left crank and there is a right pedal for the right crank. If the wrong pedal is screwed into the wrong crank, the thread will be damaged. Do not be confused. Thread to the right to tighten the right pedal and thread to the left to tighten the left pedal.

Maintenance

5

Loose is forbidden

Never ride with loose components! You will damage your equipment if you continue to practice with a part that is not tightened correctly. A simple check with the correct tool will help to prevent any unnecessary damage.

6

Spokes tension & crank set

Spokes should not be noisy! If you find that they are loose, you may need to find professional help to retention your wheel. You should also rotate the cranks on the hub often to limit asymmetrical wear of the rim and tire. Remove the cranks, clean and regrease the axle. Then rotate the wheel by 1/4 turn before reinstalling the cranks.

7

Greasing & pressure

Use the valve on the tube to check that the tire is pumped up to the appropriate pressure. Tire pressure depends on personal preference. In general, tire pressures for freestyle or road riding should be very firm, while tire pressures for Muni and trials are somewhat lower. Experiment with this until you find a tire pressure that you like.

• Always wear safety gear. Safety is your own responsibility.

